

# Product Specification

Product Model: A10-L7-L116

Product type: Cartridge

## 1. Dimension (Picture and Description)

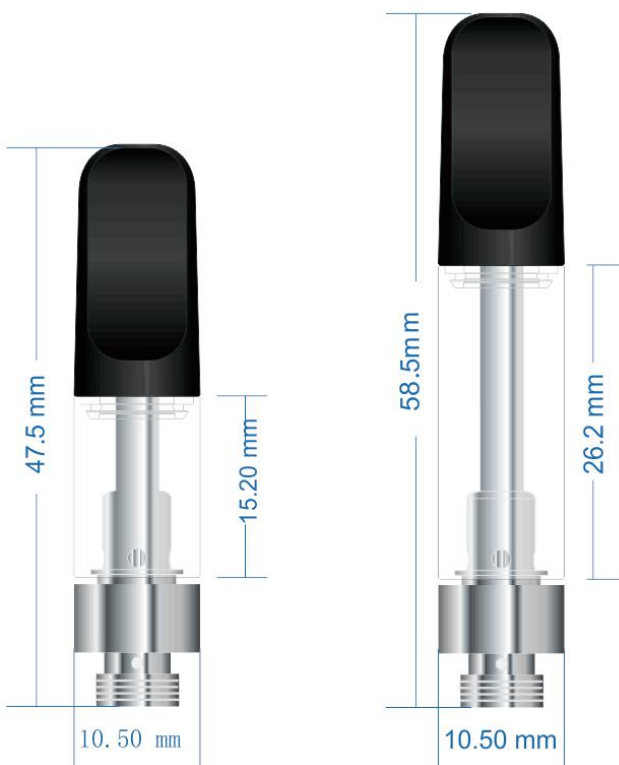

**Description:** top fill vaporizer cartridge

**Appearance:**

There are no scratches, cracks, stains, uneven colors, unclear logos, and fades on the appearance of this product.

## 2. Features

- Transpring ® next-gen heating core technology
- Pure flavor, large clouds
- Great performance with different oil

## 3. Main Technical Parameter

<b>Specifications</b>	
Tank Volume	0.5ml/1.0ml
Resistance	1.6Ω
Aperture Size	1.6mm
Aperture Number	Four
Dimension	Ø10.5x47.5mm/Ø10.5x58.5mm
Weight	9.2g/10.8g
Heating Core Material	Nichrome
Oil Drawing Material	Ceramic
Mouthpiece Material	Ceramic
Tank Material	Borosilicate glass
Connecting Rod Material	chrome plated lead-free brass
Outer Thread Material	Brass

#### **4. How to Use**

##### **1) Fill the tank with your favorite oil.**

Gently put the syringe between the airway and the outer wall of the cartridge and fill the cartridge with oil at a proper speed.

##### **Notes**

Do not inject the oil into the airway!

Do not top off the tank with oil.

##### **2) Press the mouthpiece into tank with a special jig within 2 minutes.**

We highly recommend to use capping machine to press the mouthpiece.

#### **5. Notes**

Pay attention to the shelf life of filled oil.

Handle the glass cartridge with care. Do not crush or throw the cartridge.

#### **6. Storage**

The storage temperature is  $23 \pm 5^{\circ}\text{C}$  and the humidity is  $50 \pm 10\%$  RH.

Place in a cool, dark and ventilated place.

Keep the oil-filled cartridge sealed storage and avoid direct sunlight.

The storage period should not be too long, so as not to exceed the shelf life of oil.